

Electric Fan Coil Thermostats



RAB10.1U Thermostat with manual changeover.



RAB20.1U Thermostat with exposed setpoint knob and external changeover.



RAB30.1U Thermostat with exposed setpoint knob and 3-speed fan control.



RAB90.1U 3-speed fan switch.

Description

Designed to control 2- or 4-pipe fan coil or unit ventilators, the RAB... Electric Fan Coil Thermostats are an attractive and economical solution that utilize two-wire, gas membrane technology.

Providing On/Off control, the RAB... Electric Fan Coil Thermostats are available with dual scale Fahrenheit/Celsius models with manual or external changeover.

The RAB20.1U requires an aqua sensor to initiate changeover.

Features

- Fan Speed Switch (RAB90.1U) for remote switching location (24...277 Vac)
- Two-point control algorithm for on/off control
- Line voltage
- 2-pipe or 4-pipe fan coil applications
- 3-speed fan control
- Fan on only models for ventilation
- Manual or external changeover
- Two mounting styles: electrical wall box or drywall
- Adjustable upper/lower limit stops
- Dual Fahrenheit/Celsius scale

Applications

The RAB... Electric Fan Coil Thermostats are recommended for applications in commercial or light industrial buildings in conjunction with zone valves, thermal valves, fans or thermostats.

Note:

ARG70, wall plate, is required for UL compliance in switching line voltage.

Dimensions

RAB... Room Thermostat and Wall Plate for Mounting (RAB10.1U, RAB20.1U and RAB30.1U)

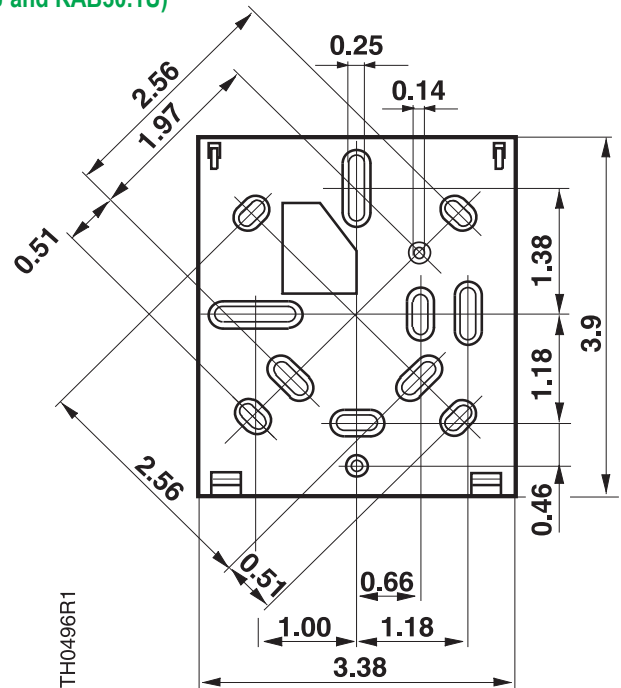
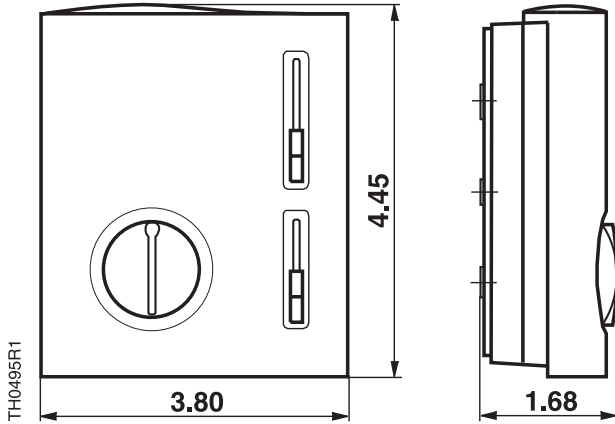

RAB90.1U and Wall Plate for Mounting

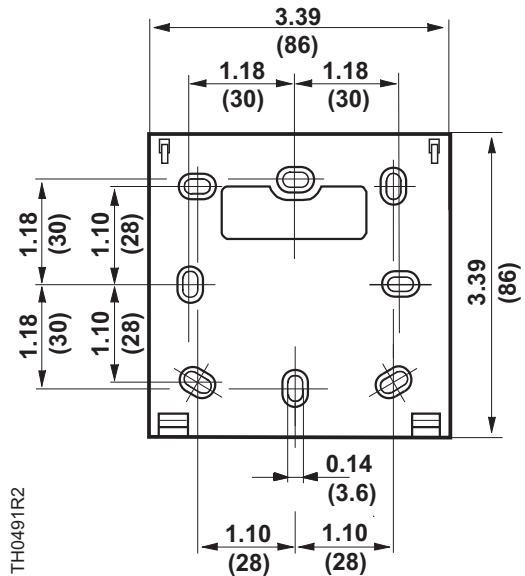
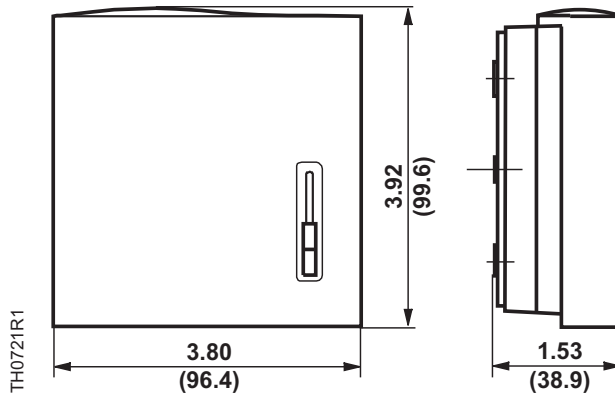

Wall Plate (ARG70) for Mounting

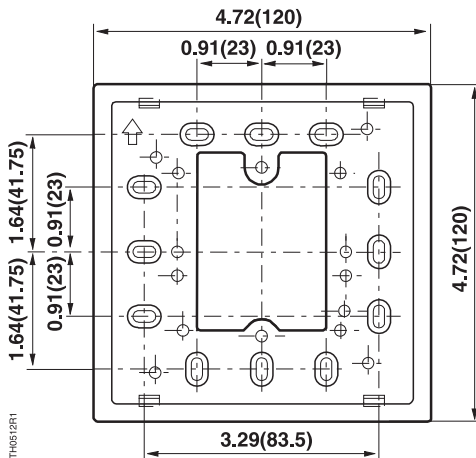

Dimensions shown in inches (mm).

Wiring Diagrams

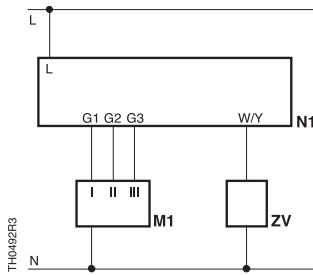

RAB10.1U...

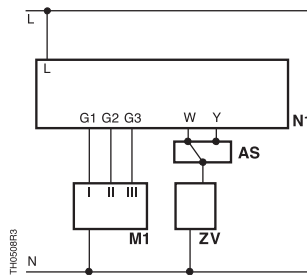

RAB20.1U...

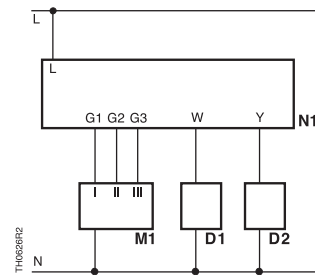

RAB30.1U...

Key

- | | | |
|---------------------|---------------------------------|-----------------------------|
| L Operating Voltage | G1 Control Output Fan Speed I | ZV Zone or Thermal Valve |
| M1 3-speed Fan | G2 Control Output Fan Speed II | W/Y Control Output Actuator |
| N Neutral | G3 Control Output Fan Speed III | AS Aqua Sensor |
| N1 Room Thermostat | | |

Operating Diagrams

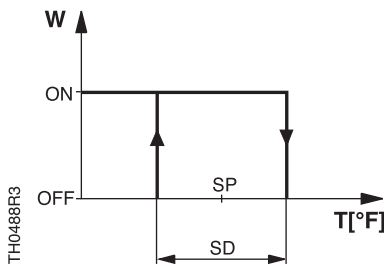

Heating Mode

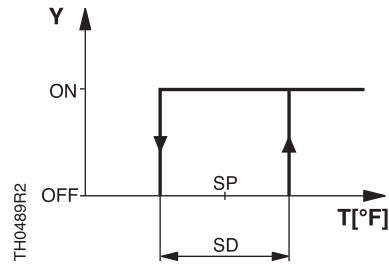

Cooling Mode

Key

- | | |
|------------------------------|-------------------------------|
| T Room Temperature | W Valve Output Signal Heating |
| SD Switching Differential | Y Valve Output Signal Cooling |
| SP Room Temperature Setpoint | |

Room Temperature Controllers for Two-pipe Fan Coil Units



RCC10U Room Temperature Controller.



RCC20U Room Temperature Controller.

Description

The RCC... Room Temperature Controllers are room temperature controllers for two-pipe fan coil units.

Features

RCC10U

- Output for on/off valve actuator
- Output for three-speed fan
- Dual setpoint temperature scale
- Control depending on the room or return air temperature
- Automatic Heating/Cooling changeover
- Operating modes: Normal, Energy Saving, Frost Protection and Off
- Operating mode changeover input for remote control
- Selectable control parameters

RCC20U

- Outputs for on/off valve actuator and electrical heater.
- Output for three-speed fan.
- Dual setpoint temperature scale.
- Control depending on the room or return air temperature (remote sensing).
- Automatic Heating/Cooling changeover.
- Operating modes: Normal, Energy Saving, Frost Protection and Off.
- Operating mode changeover input for remote control.
- Selectable control parameters.

Applications

The RCC... Series of Room Temperature Controllers are typically used for:

- Controlling Normally Open (NO) 120 Vac, two-position valves.
- Controlling room temperature in individual rooms that are heated or cooled with two-pipe fan coil units.
- Switching an electrical heater (RCC20U).
- Operating a 3-speed fan.

The RCC... Series is suitable for systems with:

- Automatic Heating/Cooling changeover.
- Heating only/Cooling only or Heating and Cooling applications.

Specifications/Product Ordering

Operating Voltage 120 Vac
Frequency 50/60 Hz
Power Consumption Maximum 4 VA
Control Outputs (Fan) 11, 10, 9 ... 120 Vac max./3A res./3.5 FLA/7.0 LRA
Control Output 3 0 to 10 Vdc
 Resolution 39 mV
 Current ±1 mA
Signal Input 2 for Changeover Sensor QAH11.1, Class 2,
 NTC resistor 3K Ω at 77°F (25°C)
Permissible Number of Thermostats Ten in Parallel, Signal Input 3
Status Input D1 and GND
 Contact Sensing 6 to 15 Vdc/3 to 6 mA
 Insulation against live voltage 4 kV
Operating Action Normally Open (NO)
Permissible Cable Length with Copper
Cable 16 AWG for Connection to Signal Input 2,
D1, and GND 262 feet (80m)
Setpoint Setting Range 50 to 85°F (10 to 30°C)

Setpoint (Energy Saving Mode), Heating 61°F (16°C)
Setpoint (Energy Saving Mode), Cooling 82°F (28°C)
Operation
 Temperature 32 to 122°F (0 to 50°C)
 Humidity <95% RH
Shipping and Storage
 Temperature -13 to +158°F (-25 to +70°C)
 Humidity <95% RH
Agency Approvals UL 873
 cUL
 Certification C22.2 No. 24-93
 Conforms to CE Requirements
Connection Terminals Solid Wires or Prepared Standard Wires
 2 X16 AWG or 1 X14 AWG
 Minimum 20 AWG
Housing Color
 Cover White and gray
 Base Gray
Degree of Housing Protection NEMA 1
Shipping Weight 0.5 lb. (0.23 kg)

A-42

RCC...	Description	Part No.
	Two-pipe fan coil unit controller, on/off output	RCC10U
	Two-pipe fan coil unit controller with additional electric heat; on/off output	RCC20U

Accessories & Service Kits **A-77**

Thermostats

Dimensions

RCC10U/20U Controller

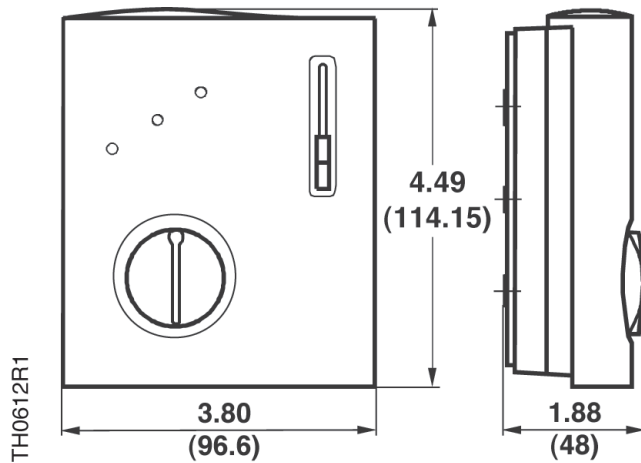

Baseplate

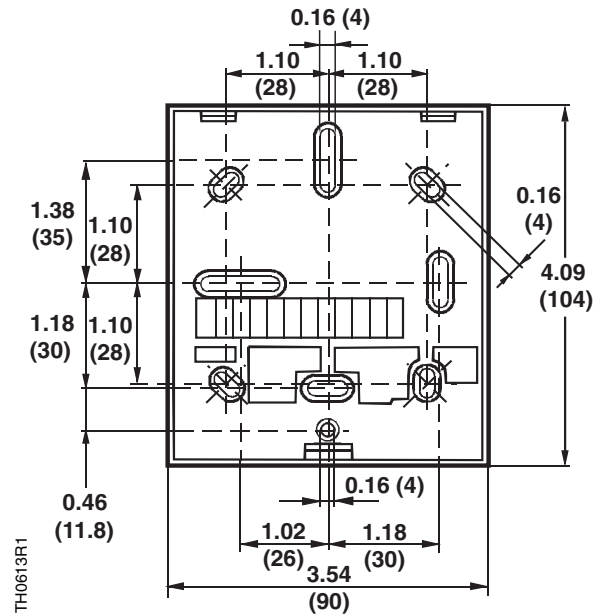

Dimensions are shown in inches (mm).

Free Energy Band™ Room Temperature Controller for Four-pipe Fan Coil Units



RCC30U Room Temperature Controller.

Description

The RCC... Free Energy Band Room Temperature Controllers are room temperature controls for four-pipe fan coil units.

Features

- Outputs for on/off valve actuators
- Outputs for three-speed fan
- Dual setpoint temperature scale
- Control depending on the room or return air temperature (remote sensing)
- Automatic Heating/Cooling changeover
- Operating modes: Normal, Energy Saving, Freeze Protection and Off
- Operating mode changeover input for remote control
- Selectable control parameters
- Free Energy Band between Heating and Cooling for energy conservation

Applications

The RCC... Series is typically used for the following applications:

- Controlling room temperature in individual rooms that are heated or cooled with four-pipe fan coil units.
- Opening or closing a Normally Closed (NC) Heating and a Normally Open (NO) Cooling, 120 Vac, two-position valve.
- Switching a three-speed fan.

Dimensions

RCC30U FEB Controller

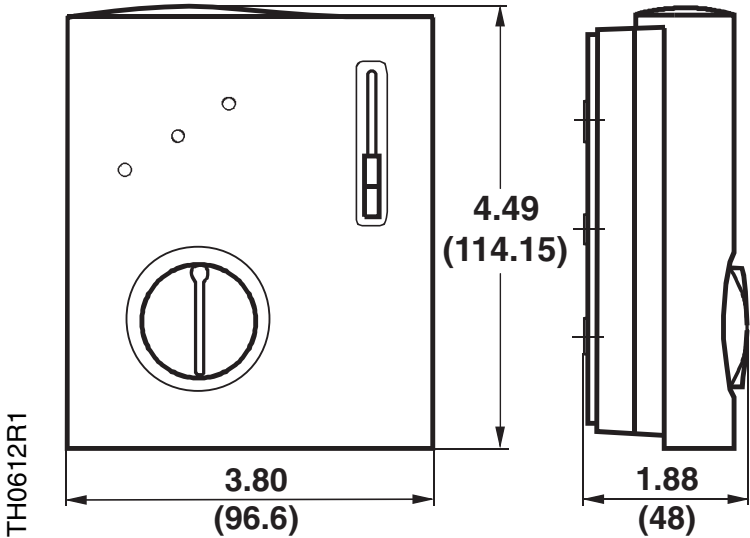

Baseplate

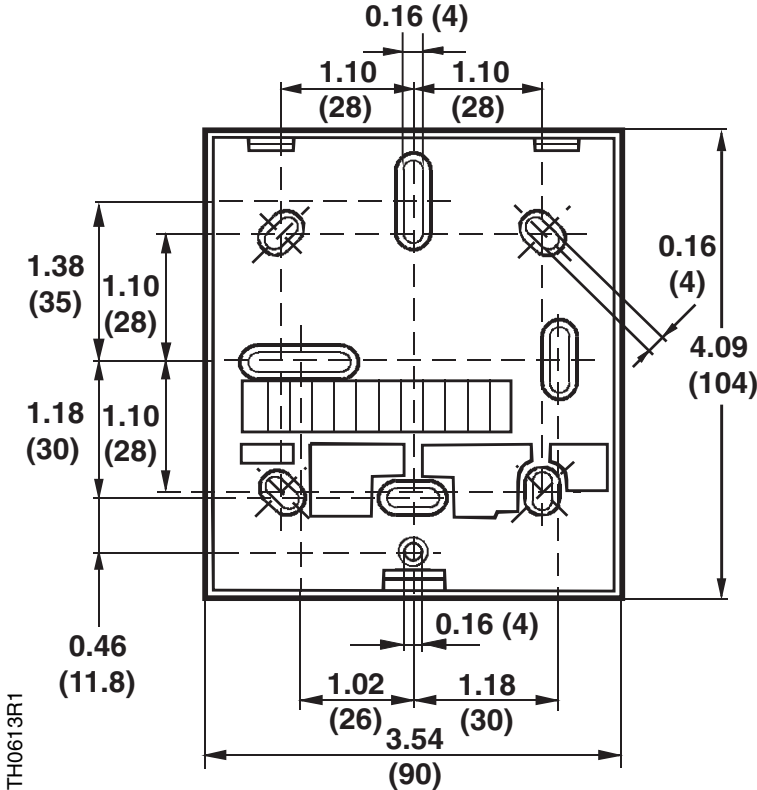

Dimensions shown in inches (mm).



TECH TIPS

Check your order status quickly and easily via our secure Order Tracker feature. To take advantage of time-saving benefits, go online to **www.usa.siemens.com/hvaccomponents**, click on site360, and register today.

Room Temperature Controllers for CAV Systems



RCU15U/RCU50U
Room Temperature Controller.



RCU50.2U Room Temperature Sensor with
manual heating/cooling changeover switch.

Description

The RCU15/50... Series microprocessor controlled CAV room controllers are designed for air only, or air and water heating and/or cooling systems. Controllers have two-position, pulse width modulation (PWM), or proportional response.

Features

- 0 to 10 Vdc output for heating or cooling (RCU50U and RCU50.2U)
- ON/OFF or PWM outputs for heating and cooling (RCU15U)
- Control depending on room or return air temperature (RCU15U)
- Automatic heating/cooling changeover (RCU15U and RCU50U)
- Manual heating/cooling changeover (RCU50.2U)
- Operating modes: Normal, Energy Saving, Freeze Protection and Standby (RCU15U and RCU50U)
- Operating modes: Normal and OFF (RCU50.2U)
- Active 0 to 10 Vdc input for setpoint shifting (RCU50U)
- Operating mode changeover input for remote control (RCU50U)
- Adjustable minimum limitation for cooling output (RCU50U)
- Operating voltage 24 Vac

Applications

Controlling individual room temperature in HVAC installations that are heated or cooled.

Controlling these types of equipment:

- Valve actuators
- Air damper actuators

Specifications/Product Ordering

Power Supply

Operating Voltage 24 Vac ±20%
 Frequency 50/60 Hz

Setpoint Setting Range 50 to 85°F (10 to 30°C)

P-band in Heating Mode

RCU50U 2 or 7°F (1 or 4°C)
 RCU50.2U (fixed) 7°F (4°C)

P-band in Cooling Mode

RCU50 1 or 3.5°F (0.5 or 2°C)
 RCU50.2 (fixed) 3.5°F (2°C)

Setpoint (Energy Saving Mode), Heating 61°F (16°C)

Setpoint (Energy Saving Mode), Cooling 82°F (28°C)

Setpoint Freeze Protection 46°F (8°C)

Setpoint Shift Temperature @ 72°F (22°C) +22.5°F (±12.5°C)

Control Action

RCU15U On/Off/PWM
 RCU50U & RCU50.2U Proportional

Control Outputs, Terminals 4 and 5 (RCU 50...)

Voltage 0 to 10 Vdc
 Current ±1 mA

Control Outputs, Terminals 7 and 8 (RCU15U)

Voltage 24 Vac ±20%
 Current 0.02 to 1A
 Cycle time PWM (selectable for terminal 7) 20s or 90s

Status Input D1 (RCU50U)

Contact sensing 6 to 15 Vdc/3 to 6 mA
 Insulation against live voltage 4 kV
 Maximum number of contacts connected in a panel 50

Status Inputs 1 and 2 (RCU50U)

Setpoint shift of +22.5°F @ 72°F (22°C) 0 to 10 Vdc
 Neutral position (no setpoint shift) 5 Vdc

Signal Input Terminals 2 and 3

for Changeover Sensor QAH11.1 safety class 2
 NTC resistor 3KΩ @ 77°F (25°C)

Maximum Copper Cable Length 16 AWG

For Input Signal terminals 1 & 2 (RCU50U) 262 feet (80m)
 For Input Signal D1 (RCU50U) 262 feet (80m)

Operation

Temperature 32 to 122°F (0 to 50°C)
 Humidity <95% RH

Shipping and Storage

Temperature -13 to 158°F (-25 to 70°C)
 Humidity <95% RH

Agency Approvals

UL listed UL 873
 Conforms to CE requirements
 cUL certified to Canadian Standard C22.2 No. 24-93

Connection Terminals

Use Solid Wires or Prepared Stranded Wires
 2 x 16 AWG or 1 x 14 AWG, 20 AWG max.

Housing Color

Cover White
 Base Gray

Shipping Weight 0.5 lb (0.23 kg)

A-48

Thermostats

RCU15/50...	Heat/Cool Changeover	Output(s)	Part No.
	Automatic	(2) On/Off or PWM	RCU15U
	Automatic	(1) 0 to 10 Vdc	RCU50U
	Manual	(1) 0 to 10 Vdc	RCU50.2U

Ordering Note: The temperature sensor, changeover mounting kit, and valve and damper actuators must be ordered separately, see table below.

Device Combinations

Description	Part No.
Remote Cable Temperature/Changeover Sensor	QAH11.1
44 lb-in NSR Air Damper Actuator	GDE16...
88 lb-in NSR Air Damper Actuator	GLB16...
Valve Actuator	SSB61U
Valve Actuator	SSC61U SSC61.5U
Valve Actuator	SQS65U SQS65.5U

Function Diagrams

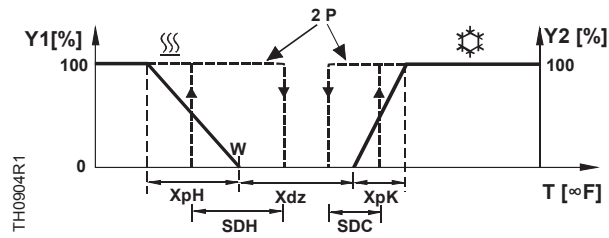

RCU15U – Heating-Cooling

Key

T	Room temperature	XpK	Proportional band cooling
Y1, Y2	Output percentage	SDH	Switching differential for heating
W	Room temperature setpoint	SDC	Switching differential for cooling
Xdz	Dead band	2 P	2-position outputs
XpH	Proportional band heating		

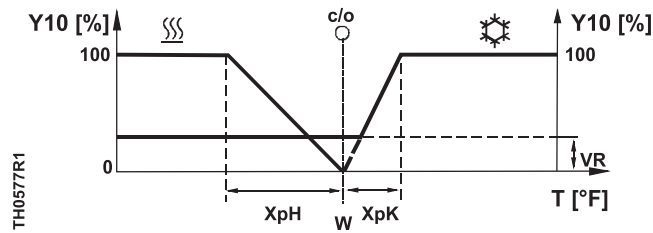

RCU50U – Heating-Cooling with Minimum Limitation Cooling

Key

T	Room temperature	XpK	Proportional band cooling
Y10	Output percentage	VR	0 to 100% minimum limitation of cooling output
W	Room temperature setpoint	c/o	Changeover
XpH	Proportional band heating		

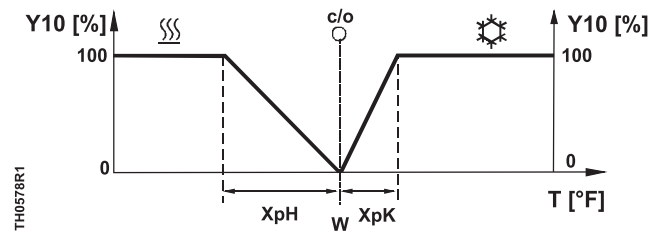

RCU50.2U – Heating-Cooling

Key

T	Room temperature	XpH	Proportional band heating
Y10	Output percentage	XpK	Proportional band cooling
W	Room temperature setpoint	c/o	Changeover

Dimensions

RCU15/50... Controller

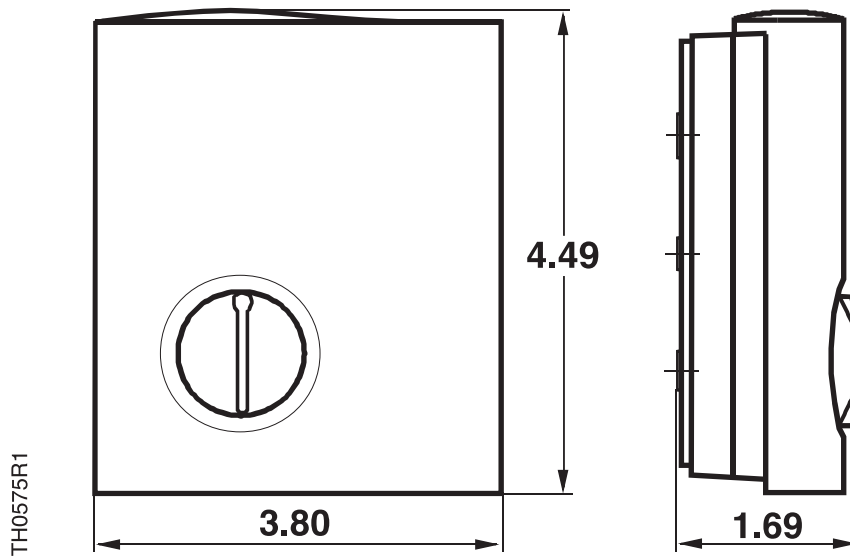

RCU15/50... Baseplate

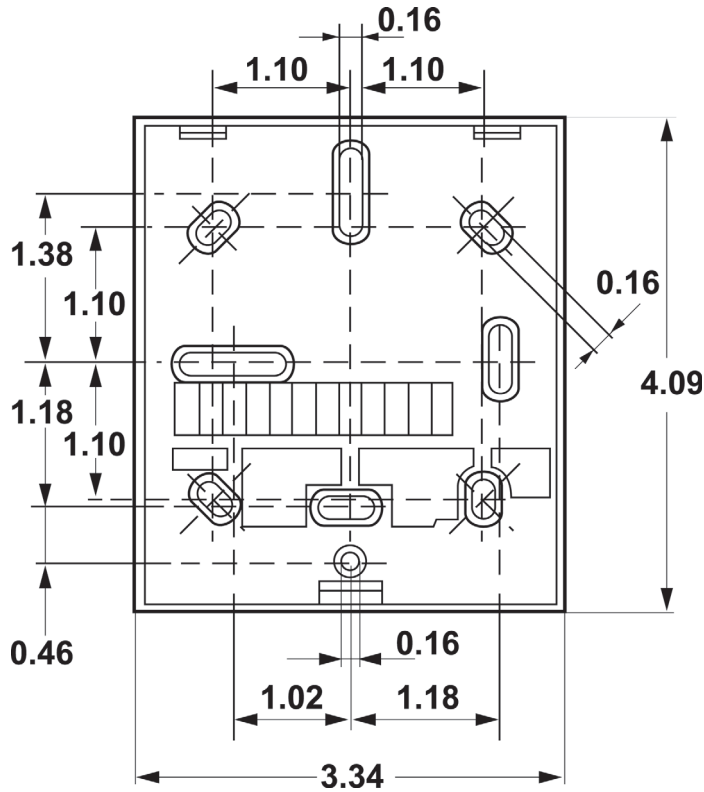

Dimensions shown in inches.

A-50

Thermostats

Room Temperature Controllers for CAV and VAV Systems



RCU61U Room Temperature Controller.

Description

The RCU61U Room Temperature Controllers are designed specifically for Constant Air Volume and Variable Air Volume Systems.

Features

- Modulating P-control
- 0 to 10 Vdc output for cooling
- Three-position output 24 Vac for heating
- Operating modes: normal, energy saving and standby
- Active 0 to 10 Vdc input for remote setpoint shifting
- Operating mode changeover input for remote control
- Adjustable minimum limitation for cooling output
- Operating voltage 24 Vac
- Ergonomic design
- Dual Fahrenheit/Celsius scale

Applications

Controlling individual room temperature in HVAC installations that are heated or cooled, the RCU61U Temperature Controllers are suited for use with VAV systems with auxiliary heating with VAV compact controllers, valve actuators, and air damper actuators.

Function Diagram

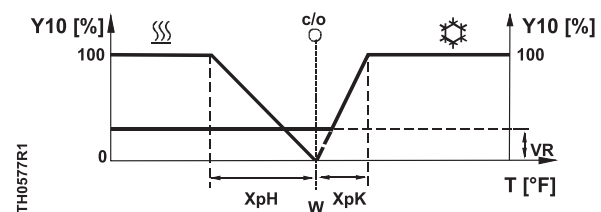

Key			
T	Room Temperature	XpK	Proportional Band Cooling
Y2, Y10	Output Percentage	VR	0 to 100% Minimum Limitation of Cooling Output
W	Room Temperature Setpoint		
XpH	Proportional Band Heating		

Specifications/Product Ordering

Power Supply

Operating Voltage 24 Vac \pm 10%
 Frequency 50/60 Hz

Setpoint Setting Range 46 to 86°F (8 to 30°C)

Maximum Control Deviation at 68°F (20°C) \pm 0.7 K

Switching Differential Heating SDH
 or P-band XpH (Selectable) 2 or 7°F (1 or 4°C)

Switching Differential Cooling SDC
 or P-band XpC (Selectable) 1 or 3.5°F (0.5 or 2°C)

Setpoint Shift Temperature @ 72°F (22°C) \pm 22.5°F (\pm °C)

Control Outputs (Cooling) 4 & 5 0 to 10 Vdc
 Voltage 24 Vac
 Current \pm 1 mA

Control Outputs (Heating) 8, 9 & 10 24 Vac \pm 20%

Motor Timing for Heat Output 150 sec. @ 60 Hz

Status Input D1

Contact Sensing 6 to 15 Vdc / 3 to 6 mA
 Insulation Against Live Voltage 4 kV
 Maximum Number of Contacts per Panel 50

Status Input B1

Setpoint Shift of 36°F (12.5 C) 0 to 10 Vdc
 Neutral Position (No Setpoint Shift) 5 Vdc

Signal Input B2 for Changeover Sensor QAH11.1 Safety Class 2

Maximum Copper Cable Length 16 AWG

For Input Signal B1/B2 (RCU61U) 262 ft. (80 m)
 For Input Signal D1 (RCU61U) 262 ft. (80 m)

Operation

Temperature 32 to 122°F (0 to 50°C)
 Humidity <95% RH

Agency Listings UL Listed 197N; Conforms to CE Requirements

Connection Terminals Use Solid Wires or Prepared Stranded Wires
 2x13 AWG or 1x16 AWG

Housing Color

Cover White
 Base Gray

Shipping Weight 0.5 lb. (0.02 kg)

A-52

Thermostats

	Description	Part No.
RCU61U	Room Temperature Controller	RCU61U

Accessories
& Service Kits

A-77

Device Combinations

Description	Type Reference
Valve Actuator	SSA81 SSB61U SSB81 SSC81
Damper Actuator	GLB16x GCA16x GGB16x GDE16x

Dimensions

RCU61U Controller

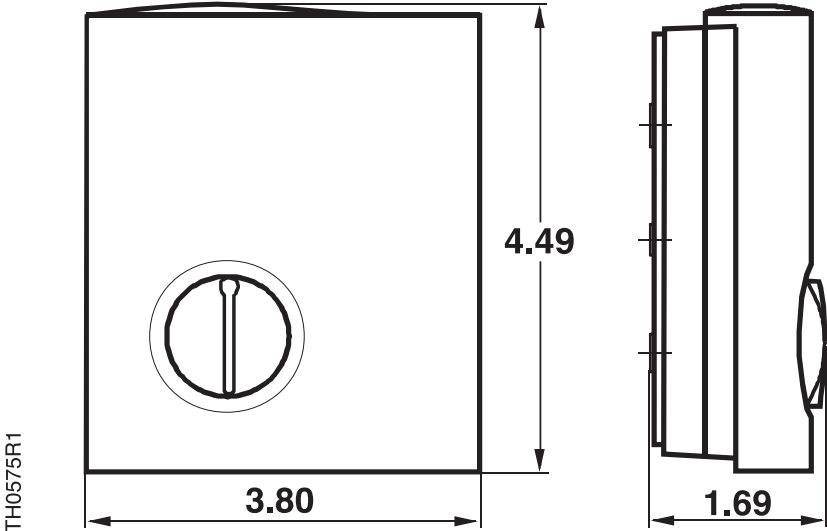

Baseplate

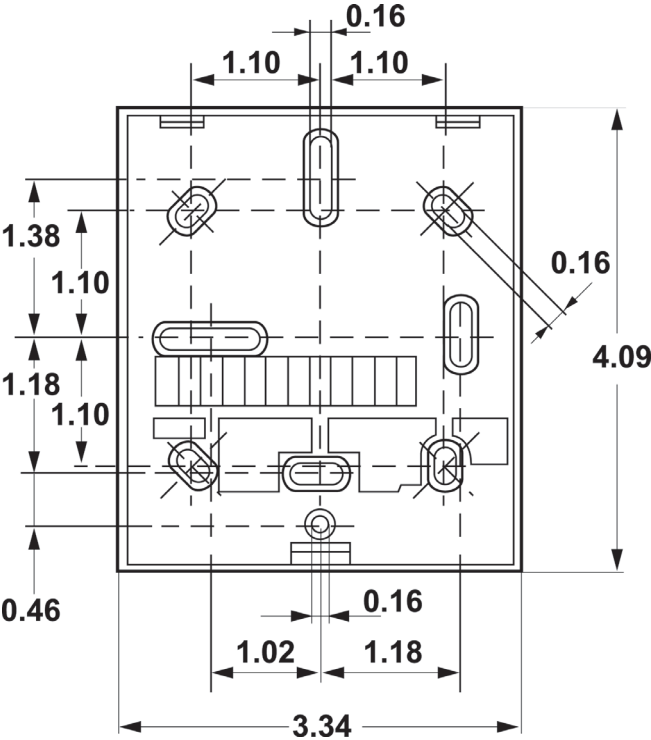

Dimensions shown in inches.

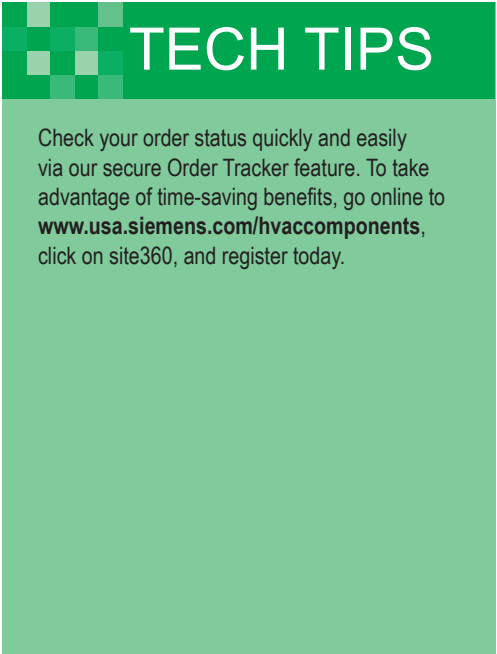

TECH TIPS

Check your order status quickly and easily via our secure Order Tracker feature. To take advantage of time-saving benefits, go online to www.usa.siemens.com/hvaccomponents, click on site360, and register today.

Room Temperature Controller with Two 0 to 10 Vdc Outputs

New!



RLA162.5U Room Temperature Controller

Description

Room temperature controller for basic ventilation, air conditioning and heating systems. Compact design with two analog, 0 to 10 Vdc control outputs for heating and/or cooling, and digital input for pump or fan.

Features

- Automatic heat/cool changeover.
- Automatic day/night setpoint changeover via external contact.
- Room temperature control through modulating control of valve or damper actuators with selectable operating action of control signals for heating only, cooling only, or heating and cooling in sequence.
- Relay input for fan pump or other controls.
- Minimum limitation of the supply air temperature.
- Outputs are independently selectable direct acting (DA) or reverse acting (RA).
- Adjustable proportional band.

Applications

- Single-stage heating
- Single-stage cooling
- Two-stage heating
- Heating and cooling in sequence
- Minimum limitation of supply air

Devices that can be controlled:

- Modulating heating or cooling valve actuators
- Modulating air damper actuators
- Circulating pumps, charging pumps, and boilers

A-55

Thermostats

Specifications/Product Ordering

Power Supply

Operating Voltage 24 Vac \pm 20/-25%
 Frequency 50/60 Hz
 Power Consumption Maximum 2 VA

Setpoint Temperature Differential

Adjustment Range 46 to 86°F (8 to 30°C)

Night Setpoint Differential From

Day Setpoint, Adjustable 0 to 18°F (0 to 10 K)

Proportional-band 2 to 90°F (1 to 50 K)

Integral Action Time with PI Control 600 Seconds (10 minutes)

Dead Zone with Heating/Cooling in Sequence 1.8°F (1 K)

Relay Input (Fan) 13, 20 24 Vac

Control Outputs 18, 19, Modulating, P or P + I Control Algorithm

Voltage 0 Vdc to 10 Vdc, Continuous
 Current Maximum 1 mA

Maximum Cable Length Copper (16 AWG)

For Signal Input 5, 11 262 feet (80 m)

Contact Input (D1-GND) 3 to 6 mA

Operation

Temperature 32 to 122°F (0 to 50°C)
 Humidity <95% RH

Transport

Temperature -13 to 158°F (-25 to 70°C)
 Humidity <95% RH

Regulatory Approvals

Degree of protection NEMA 1
 UL listing UL 916
 cUL Canadian Standard C22.2 No. 205-M1983

Connection Terminals for solid wires

or stranded wires 2 x 16 AWG or 1 x 14 AWG

Sensor

Sensing Element Siemens-Ni 1000 Ω at 32°F (0°C)

Shipping Weight 1.40 lb (0.64 kg)

Wiring Diagrams

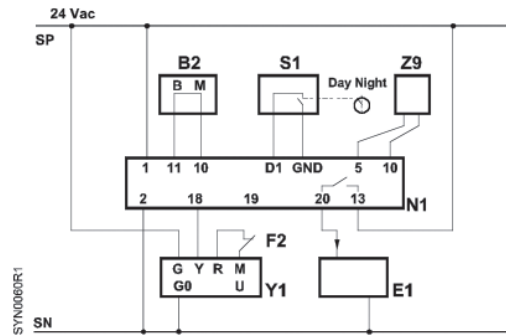

RLA162.5U

Key

- B2 Heat/cool changeover sensor
- E1 Fan or auxiliary unit
- F2 Low temperature detection thermostat
- N1 Room temperature controller (RLA162.5U)
- S1 Time clock or switch for day/night setpoint changeover
- Y1 Heating valve actuator
- Z9 Limit controller (RLM162U) as a limiter

A-56

Thermostats

RLA162.5U	Description	Part No.
	Room Temperature Control with Minimum Limitation and Automatic Day/Night Changeover	RLA162.5U

Ordering Note: The temperature sensor, kit, and valve and damper actuators must be ordered separately, see table below.

Device Combinations

Actuators and controls must meet the following specifications:

- Operating voltage 24 Vac
- Control input: modulating 0 to 10 Vdc

Description	Type Reference
OpenAir™ GDE Series Damper Actuator with 44 lb/in torque	GDE161.1T GDE161.1P
OpenAir™ GLB Series Damper Actuator with 88 lb/in torque	GLB161.1P
OpenAir™ GMA Damper Actuator 62 lb/in torque	GMA161.1P GMA161.1U
Accessory wall escutcheon	ARG70
Air duct temperature controller (as a minimum limiter)	RLM162U
Cable changeover sensor	QAP22

Function Diagrams

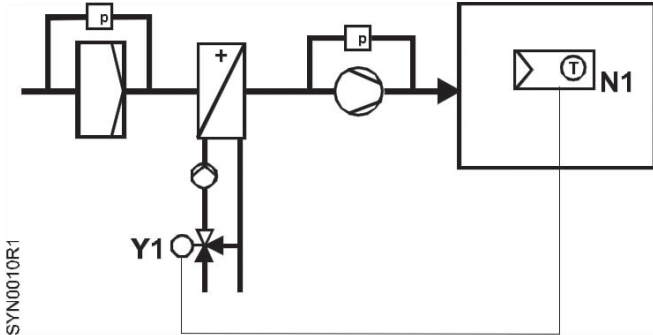

RLA162.5U Room Temperature Controller

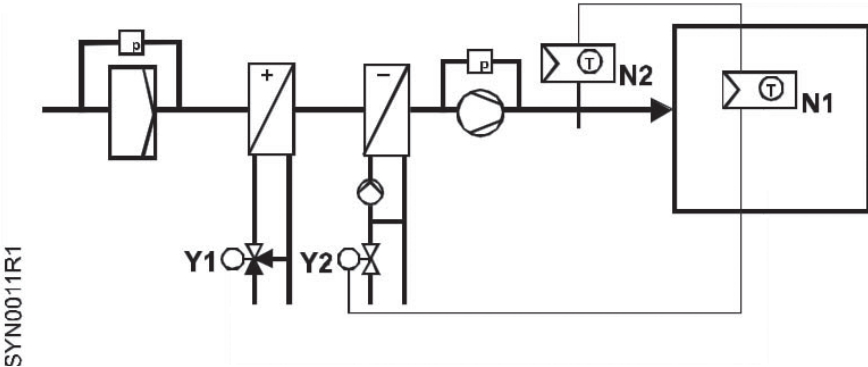

RLA162.5U and RLM162U Room Temperature Controllers

- Key**
- N1 Room Temperature Controller (RLA162.5U)
 - N2 Air Duct Temperature Controller (RLM162U) — controls minimum or maximum limitation of discharge air
 - Y1 Heating valve
 - Y2 Cooling valve

Dimensions

RLA162.5U Controller

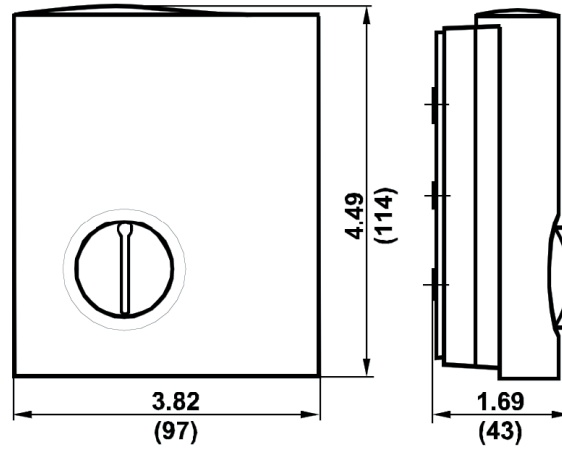

A-58

Thermostats

RLA162.5U Baseplate

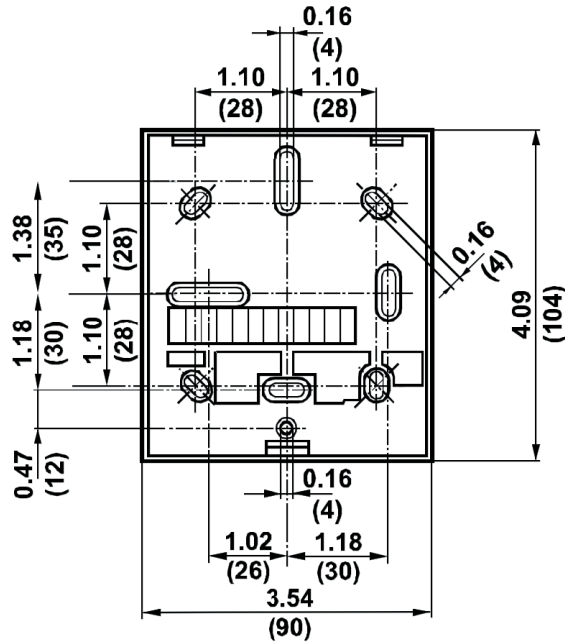

Dimensions shown in inches (mm).

Room Temperature Controllers with LCD for Heating and Cooling Systems



RDU20U/RDU50U Room Temperature Controller.



RDU50.2U Room Temperature Controller.

Description

The RDU Series Room Controller with LCD is designed for 2-pipe heating and cooling systems.

Features

- Liquid crystal display
- Modulating Proportional + Integral (P+I) control
- Control depending on room or remote air temperature
- Output for a 0 to 10 Vdc actuator (RDU50U and RDU50.2U)
- Output for a floating (3-position) or on/off output actuator (RDU20U)
- Adjustable actuator run time (RDU20U)
- Automatic heating/cooling changeover (RDU20U and RDU50U)
- Manual heating/cooling changeover (RDU50.2U)
- Operating modes: Normal, Energy Saving and Off (RDU20U and RDU50U)
- Operating mode changeover input for day/night remote control
- Selectable installation and control parameters
- Adjustable minimum limitation for cooling output (RDU50U)
- Optional selectable Direct Acting or Reverse Acting output (RDU50U and RDU50.2U)
- Selectable display of room temperature or setpoint
- Fahrenheit or Celsius selectable display
- Minimum and maximum setpoint limitation
- Operating voltage, 24 Vac

Applications

The RDU...Series of Room Temperature Controllers are used for individual room temperature control in heating or cooling HVAC applications.



TECH TIPS

Visit us on the web at:
www.usa.siemens.com/hvaccomponents,
for printable product specification sheets on all
products in this catalog.

Room Temperature Controller with LCD



RDX42.22U Room Temperature Controller with LCD.

Description

The RDX... Room Temperature Controller with LCD is a controller for heat pump systems with reversing valve, or standard heating and cooling with optional electric heater, one- or two-stage heating and one-stage cooling.

Features

- Outputs for one-stage compressor and reversing valve or on/off valve actuators
- Output for auxiliary electric heating
- Output for a one-speed fan
- Room or return air temperature control
- Manual heating/cooling changeover
- Operating modes: Normal (heating, cooling), Energy Saving, Off
- Operating mode changeover input for remote control
- Selectable installation and control parameters
- Operating voltage 24 Vac

Applications

The RDX... Series of Room Temperature Controllers are used for control of the following:

- Heat pump systems with reversing valve, optional electric heater, one- or two-stage heating and one-stage cooling.
- Four pipe standard heating and cooling systems.
- Room temperature in individual rooms that are heated or cooled with four-pipe fan coil units and optional electric heating.
- Opening and closing a valve.
- Switching a one-speed fan.

Specifications/Product Ordering

Operating Voltage 24 Vac \pm 20%
Frequency 50/60 Hz
Power Consumption Maximum 6 VA
Control Output FAN 24 Vac
 Rating Maximum 5(3)A
Control Outputs Cooling and Heating 24 Vac
 Rating Maximum 5(3)A
Control Output Aux. Heating 24 Vac
 Rating Maximum 5(3)A

Remote Temperature Sensor
Status Input 8-7 QAH11.1 Safety Class II
 NTC resistor 3 k ohm at 77°F (25°C)

Status input D1 and GND
 Operating Action Selectable Normal Open (NO)
 Contact Sensing Normal Closed (NC)
 Insulation Against Line Voltage SELV 6 to 15 Vdc/3 to 6 mA, 4kV
 Reinforced Insulation

Permissible Cable Length with Copper Cable
2 X16 AWG or 1 X14 AWG for Connection to
Terminals 8 and D1 262 ft. (80 m)

Setpoint Setting Range 46 to 95°F (8 to 35°C)
Control Deviation at 77°F (25°C) Maximum + 1°F (0.5 K)
 Setting Range Factory Setting
Switching Differential in Heating Mode (adj) 1 to 7°F 3.5°F (2 K)
Switching Differential in Cooling Mode (adj) 1 to 7°F 2°F (1 K)
Setpoint Differential WD (Adjustable) 1 to 9°F 3.5°F (2 K)
Setpoint (Energy Saving Mode), Heating 46 to 64°F 61°F (16°C)
Setpoint (Energy Saving Mode), Cooling 75 to 95°F 82.5°F (28°C)

Operation
 Temperature 32 to 122°F (0 to 50°C)
 Humidity <95% RH

Shipping and Storage
 Temperature -13 to +158°F (-25 to +70°C)
 Humidity <95% RH

Agency Approvals Conforms to CE Requirements
 NEMA 1

Connection Terminals Use Solid Wires or
 Prepared Stranded Wires. 22 AWG to 14 AWG

Housing Cover Color White

Shipping Weight 0.5 lb. (0.225 kg)

A-64

Thermostats

RDX...	Description	Part No.
	Room Temperature Controller	RDX42.22U

Wiring Diagrams

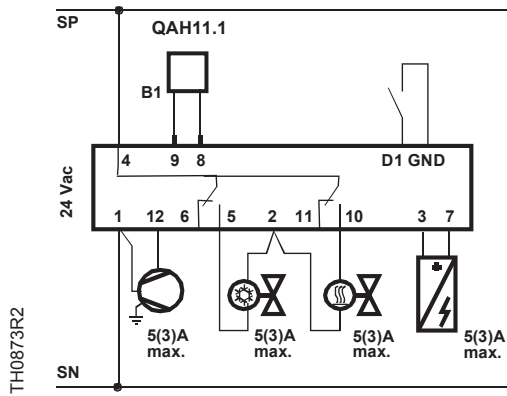

RDX... Four-pipe System Wiring

- Key**
- 6 Cooling output NC contact
 - 5 Cooling output NO contact
 - 11 Heating output NC contact
 - 9 Heating output NO contact

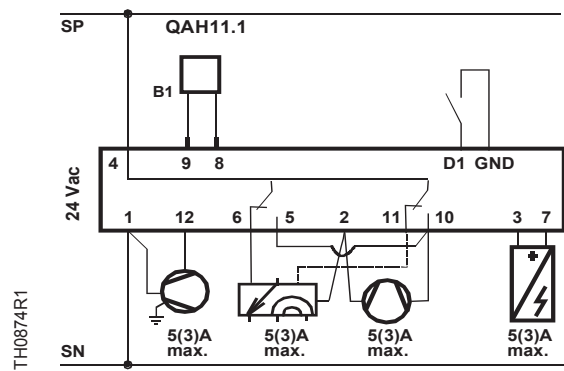

RDX... Heat Pump Wiring

- Key**
- 6 Cooling output NC contact for reversing valve
 - 5 Cooling output NO contact for compressor
 - 11 Heating output NC contact for reversing valve
 - 9 Heating output NO contact for compressor

Note: Outputs 5 and 10 must be wired together for compressor control

Dimensions

RDX... Controller

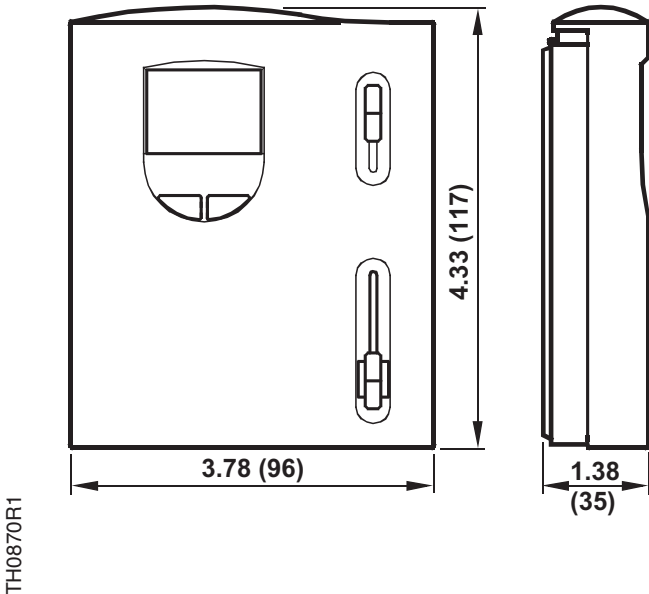

Baseplate

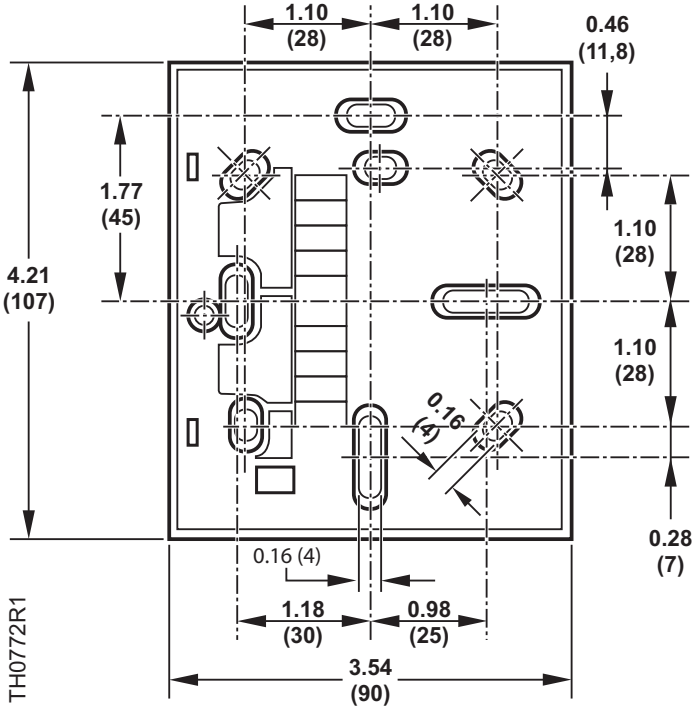

Dimensions shown in inches (mm).

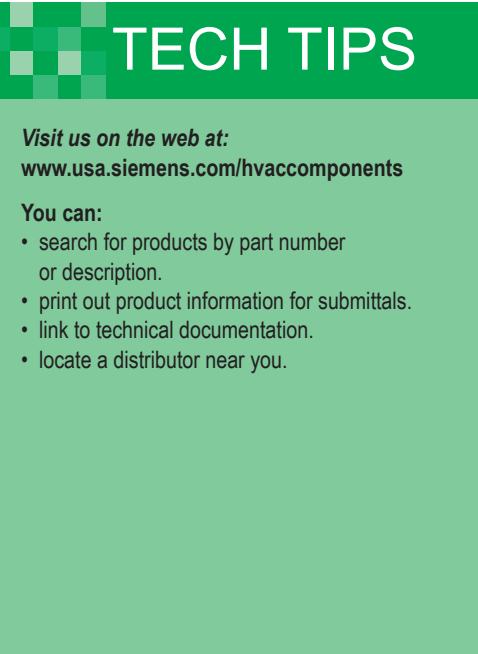

TECH TIPS

Visit us on the web at:
www.usa.siemens.com/hvaccomponents

You can:

- search for products by part number or description.
- print out product information for submittals.
- link to technical documentation.
- locate a distributor near you.

Room Temperature Controllers with LCD for Two-Pipe Fan Coil Units

New!



RDF20U Room Temperature Controller with LCD for Two-Pipe Fan Coil Units with Electric Heat

Description

Room temperature controller with LCD for two-pipe fan coil units.

Features

RDF10U

- Output for an on/off valve actuator

RDF20U

- Output for an on/off valve actuator and an electric heater

RDF50.1U

- Modulating PI control
- Output for a 0 to 10 Vdc valve actuator

RDF60.1U

- Modulating PI control
- Output for a three-position valve actuator

ALL MODELS

- Outputs for a three-speed fan
- Control depending on the room or the return air temperature
- Automatic heating/cooling changeover
- Continuous heating or cooling mode
- Operating modes: Normal, Economy and Standby
- Operating mode changeover input for remote control (Day/Night)
- Air movement control function for avoiding damage resulting from moisture
- Selectable installation and control parameters
- Display of room temperature or setpoint (selectable)
- Electronic minimum and maximum setpoint limits
- Operating voltage 24 Vac

Applications

Typical use for RDF10U:

- Control of the room temperature in individual rooms that are heated or cooled with two-pipe fan coil units.
- Opening or closing a valve and switching a three-speed fan.

Typical use for RDF20U:

- Control of the room temperature in individual rooms that are heated or cooled with two-pipe fan coil units equipped with an electric heater.
- Opening or closing a valve, switching a three-speed fan, and switching an electric heater.

Typical use for RDF50.1U:

- Control of the room temperature in individual rooms that are heated or cooled with two-pipe fan coil units.
- For opening and closing a 0 to 10 Vdc valve operating on 24 Vac and for switching a three-speed fan.

Typical use for RDF60.1U:

- Control of the room temperature in individual rooms that are heated or cooled with two-pipe fan coil units.
- Opening and closing a three-position valve operating on 24 Vac and for switching a three-speed fan.

A-67

Thermostats

Specifications/Product Ordering

Power Supply

Operating Voltage 24 Vac, +20/-25%

Frequency 50/60 Hz

Power Consumption 6 VA maximum

Fan Control Outputs

RDF10U, RDF20U, RDF60.1U 12, 11, 10-N 24 Vac

Rating 5 (3) A maximum

Valve Control Output 4-2 (NO) 24 Vac

Rating 5 (3) A maximum

Valve Control Output 5-2 (NC) 24 Vac

Rating 5 (3) A maximum

RDF20U Electric Heating Control Output 6-2 (NO) 24 Vac

Rating 5 (3) A maximum

RDF60.1U Valve Control Output 4, 6, 2 24 Vac

Rating 5 (3) A maximum

RDF50.1U Valve Control Output 1-6 SELV 0 to 10 Vdc

Resolution 39 mV

Effective Current ±1 mA maximum

Return Air Temperature Sensor QAH11.1 safety class II

RDF10U, RDF20U, RDF60.1U

Status Input 8-9 NTC resistor 3 kΩ at 77°F (25°C)

RDF50.1U

Status Input 4-3 NTC resistor 3 kΩ at 77°F (25°C)

Heat/Cool Changeover QAH11.1, safety class II

RDF10U, RDF20U, RDF60.1U

Status Input 7-8 NTC resistor 3 kΩ at 77°F (25°C)

RDF50.1U

Status Input 2-3 NTC resistor 3 kΩ at 77°F (25°C)

Status Input D1 and GND

Contact Sensing SELV 6 to 15 Vdc/3 to 6 mA

Insulation Against Live Voltage 4 kV, reinforced insulation

Operating Action Selectable (NO/NC)

Permissible Cable Length With Copper 262 ft (80 m) cable
14 AWG for connection to terminals 7, 8, 9 and D1, GND

Setpoint Setting Range 41° to 95°F (5° to 35°C)

Control Deviation at 77°F (25°C) ±1°F (0.5 K) maximum

Switching Differential In Heating Mode, Adjustable 2 K (3.6°F)

Switching Differential In Cooling Mode, Adjustable 1 K (1.8°F)

Setpoint, Economy Mode, Heating, Adjustable 61°F (16°C)

Setpoint, Economy Mode, Cooling, Adjustable 82°F (28°C)

Setpoint, Standby, Heating, Adjustable 46°F (8°C)

Setpoint, Standby, Cooling, Adjustable OFF

Operation

Temperature 32° to 122°F (0° to 50°C)

Humidity <95% RH

Transport and Storage

Temperature -13° to 158°F (-25° to 70°C)

Humidity <95% RH

UL Listing UL 873

Connection Terminals Solid wires or prepared stranded wires
2 x 16 AWG or 1 x 14 AWG

Housing Front Color White (RAL 9003)

Weight 0.5 lb (0.23 kg)

A-68

Thermostats

	Description	Part No.
RDF	Room Temperature Controller with LCD for Two-Pipe Fan Coil Units	RDF10U
	Room Temperature Controller with LCD for Two-Pipe Fan Coil Units with Additional Electric Heat	RDF20U
	Room Temperature Controller with LCD for Two-Pipe Fan Coil Units with Modulating 0 to 10 Vdc Output	RDF50.1U
	Room Temperature Controller with LCD for Two-Pipe Fan Coil Units and Output for 3-Position Actuator	RDF60.1U

Accessories
& Service Kits

A-91

Device Combinations

Description	For Use With Controllers	Type Reference
Temperature Sensor	RDF10U, RDF20U, RDF50.1U, RDF60.1U	QAH11.1
Two-way and Three-way Zone Valves	RDF10U, RDF20U, RDF50.1U, RDF60.1U	599 Series
Zone Valve Actuator	RDF10U, RDF20U	SF Series
Zone Valve Actuator	RDF50.1U, RDF60.1U	SSA61 Series
Zone Valve Actuator	RDF50.1U, RDF60.1U	SSB61U Series

Dimensions

RDF... Controller

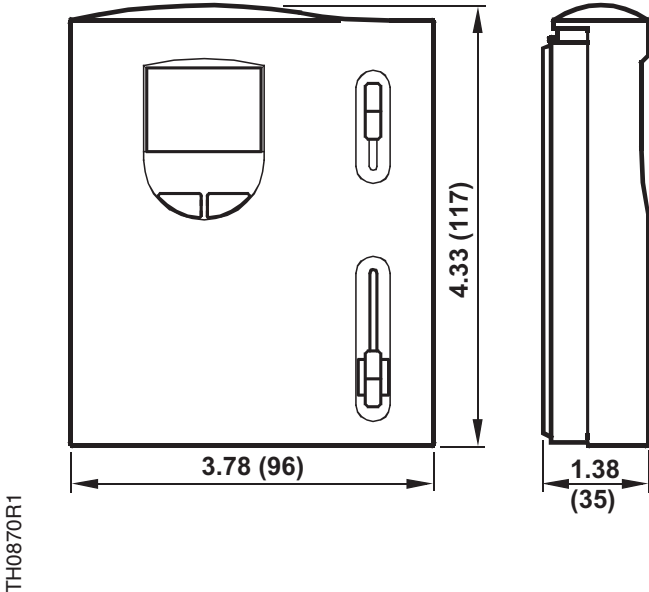

Baseplate

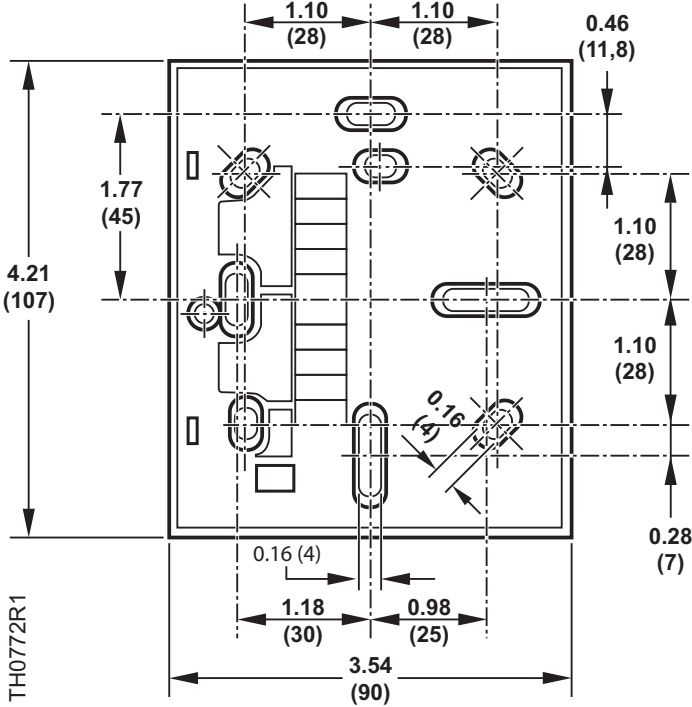

Dimensions shown in inches (mm).



TECH TIPS

Check your order status quickly and easily via our secure Order Tracker feature. To take advantage of time-saving benefits, go online to **www.usa.siemens.com/hvaccomponents**, click on site360, and register today.

Electric Surface Mounted/High Temperature Limit Control Thermostats



141-0522 Electric Surface Mounted Thermostat.

141-0530 Electric High Temperature Limit Control Thermostat.

Description

The 141 Electric Surface Mount Thermostats are single setpoint electric thermostats for high or low limit control; surface mounted or duct mounted models available.

Features

Electric Surface Mounted Thermostat

- Can be mounted horizontally, vertically or at an angle.
- Visual setpoint indication through cover

Electric High Temperature Limit Control Thermostat

- Liquid-filled, rigid bulb sensing unit
- Adjustable high temperature limit stop
- Manual reset to close contacts

Applications

141 Surface Mounted Thermostat

The 141 Surface Mounted Thermostat is ideal as a low or high limit control on unit heaters. Also can be used as a convector or fan coil changeover control for automatically selecting the heating or cooling function based on water temperature.

141 Electric High Temperature Thermostat

The 141 Electric High Temperature Thermostat is normally located in a duct system and wired to shut down air conditioning or ventilating fans when the air temperature exceeds 125°F (52°C), which would occur during a fire.

This thermostat can also be used as a high limit control for a warm air system when a “lockout” type control is desired or required by code.

A-71

Thermostats

Typical Connections

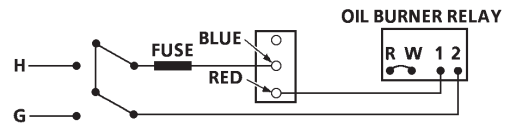

Typical High Limit Wiring.

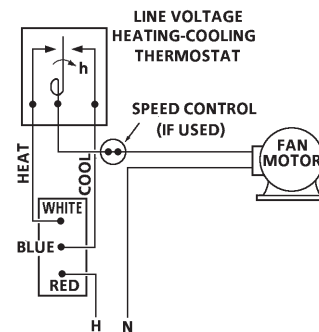

Typical Changeover Wiring.

Electric Low Temperature Detection Thermostats



134 Electric Low Temperature Detection Thermostat.

Description

The 134 Electric Low Temperature Detection Thermostat is a remote bulb instrument with a Single Pole, Double Throw switch. Any one foot of the capillary element actuates the thermostat switch, making this control ideal for the protection of large coils where air stratification could cause localized freezing conditions.

Features

- Compact and durable construction
- Adjustable concealed, low and high range limit stops with a fixed differential
- Available with manual or automatic reset
- Electroplated copper capillary tube for sensitivity and durability
- Switches 120 V or 20 Vac
- Universal mounting bracket included

Applications

The 134 Electric Low Temperature Detection Thermostats are ideally suited for detecting potential freeze-up conditions of heating coils, cooling coils, liquid heating pipes, and similar applications.

Typical Connections

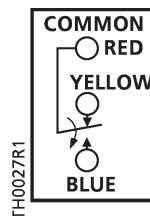
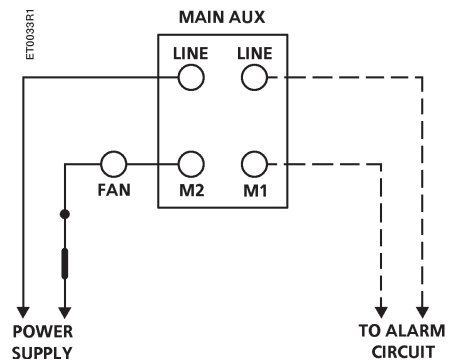

OPEN ON RISE

Red to Yellow opens on temp. decrease below set point.
Red to Blue closes on temp. decrease below set point.

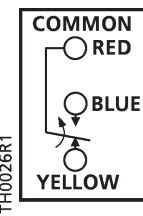

CLOSE ON RISE

Red to Blue closes on temp. decrease below set point.
Red to Yellow opens on temp. decrease below set point.

Specifications/Product Ordering

Part No. 134-1504

Dimensions 4" W x 3.25" H x 2.5" D
(102 mm W x 83 mm H x 65 mm D)

Shipping Weight 2.4 lb. (1.1 kg)

Part No. 134-1510

Dimensions 2.31" W x 3.19" H x 2.31" D
(59 mm W x 81 mm H x 59 mm D)

Shipping Weight 1.8 lb. (0.8 kg)

Part No. 134-1511

Dimensions 2.31" W x 3.19" H x 2.31" D
(59 mm W x 81 mm H x 59 mm D)

Shipping Weight 1.8 lb. (0.8 kg)

**Accessories
& Service Kits** **A-91**

	Temperature Range	Switch Action	Bulb Size	Reset Action	Part No.
134	35 to 45°F (1.7 to 7.2°C)	SPDT	1/8" x 20' (3 mm x 6 m)	Automatic	134-1510
	35 to 45°F (1.7 to 7.2°C)	SPDT	1/8" x 20' (3 mm x 6 m)	Manual	134-1511
	15 to 55°F (-9.4 to +12.8°C)	DPST, 4-wire 2 Circuit	1/8" x 20' (3 mm x 6 m)	Manual	134-1504



A-74

Thermostats



Part No. in black box Ships same day when requested through Rapid Response™ shipping. See page 1 for details.

SIEMENS